

# ENABLERS OF THE SUCCESSFUL IMPLEMENTATION OF THE STRATEGY OF TECHNOLOGICAL INNOVATION IN HIGHER EDUCATION

Sultana Fayez Alhaqbani \*,  
Nadia Abdelhamid Abdelmegeed Abdelwahed \*\*

\* Department of Business Management, College of Business Administration, King Faisal University, Al-Ahsa, Saudi Arabia

\*\* Corresponding author, Department of Business Management, College of Business Administration, King Faisal University, Al-Ahsa, Saudi Arabia  
Contact details: King Faisal University, P. O. Box 400, Al-Ahsa 31982, Saudi Arabia



## Abstract

**How to cite this paper:** Alhaqbani, S. F., & Abdelwahed, N. A. A. (2024). Enablers of the successful implementation of the strategy of technological innovation in higher education. *Corporate & Business Strategy Review*, 5(2), 18–28.  
<https://doi.org/10.22495/cbsrv5i2art2>

Copyright © 2024 The Authors

This work is licensed under a Creative Commons Attribution 4.0 International License (CC BY 4.0).  
<https://creativecommons.org/licenses/by/4.0/>

**ISSN Online:** 2708-4965  
**ISSN Print:** 2708-9924

**Received:** 30.09.2023  
**Accepted:** 10.04.2024

**JEL Classification:** L1, L2, L6, O3, Q5  
**DOI:** 10.22495/cbsrv5i2art2

Technological innovation has emerged as a formidable challenge for higher education institutions in the contemporary landscape. The present study explores the enablers of the successful implementation of technological innovation in Saudi Arabian higher education. We based this study's conceptual framework on a rigorous literature review like Wu et al. (2002), Kihn (2010), and Packendorff et al. (2014). The study applied quantitative methods and collected 220 valid samples from employees of higher education institutions in Saudi Arabia through personal visits and online questionnaires. Employing structural equation modeling (SEM), the results of the study found a negative effect of project leadership (PL) on the implementation effectiveness of technological innovation (IETE). Further, the results demonstrate a positive significant impact of financial resources (FR) and top management style (TMS) on IETE. The study findings would provide valuable insights and evidence-based recommendations to practitioners and scholars in innovation management and organizational leadership. This study can inform strategic decisions, resource allocation, and leadership development within organizations, ultimately enhancing their ability to adapt to technological changes and leverage innovation for sustainable success.

**Keywords:** Project Leadership, Financial Resources, Top Management Style, Implementation of Technological Innovation, Higher Education Institutes

**Authors' individual contribution:** Conceptualization — N.A.A.A.; Methodology — S.F.A. and N.A.A.A.; Software — S.F.A.; Validation — N.A.A.A.; Formal Analysis — S.F.A.; Investigation — S.F.A. and N.A.A.A.; Resources — N.A.A.A.; Data Curation — S.F.A. and N.A.A.A.; Writing — Original Draft — S.F.A. and N.A.A.A.; Writing — Review & Editing — N.A.A.A.; Visualization — N.A.A.A.; Supervision — N.A.A.A.; Project Administration — N.A.A.A.; Funding Acquisition — N.A.A.A.

**Declaration of conflicting interests:** The Authors declare that there is no conflict of interest.

**Acknowledgements:** The Authors thank the King Faisal University for awarding the Deanship of Scientific Research, Vice Presidency for Graduate Studies and Scientific Research, King Faisal University, Saudi Arabia [Project Grant No. 5662].

## 1. INTRODUCTION

Technology innovation is a driving factor behind the competitiveness and sustainability of organizations across industries in today's quickly changing business world (Mahardhani, 2023). As technology advances at an unprecedented pace, businesses must invest in and implement innovative solutions to stay ahead of the curve (M. Wang et al., 2023). However, the successful implementation of technological innovations is a multifaceted challenge that involves not only the technology itself but also the leadership guiding the project, the financial resources allocated to it, and the overarching management style within the organization (Zaman et al., 2023).

In the literature, several factors play a pivotal role in fostering the implementation effectiveness of technological innovation (IETE), focusing on higher education in Saudi Arabia. However, there is still a gap in the literature concerning the integrated examination of project leadership (PL), financial resources (FR), and top management style (TMS) within the Saudi context, despite their recognized importance in driving technological development and innovation (Liao et al., 2017; Jia et al., 2018; Li et al., 2023; Zhang et al., 2023; Costa et al., 2023; Siddiquei et al., 2023). In today's dynamic landscape of higher education in Saudi Arabia, technological innovation is emerging as a catalyst for transformation, enhancing the quality of teaching and learning and facilitating administrative processes (Akinwale & AboAlsamh, 2023). With a keen focus on harnessing the power of technology to improve educational outcomes, institutions of higher education in Saudi Arabia are investing substantially in innovative solutions (Yikun et al., 2023). However, the successful integration of technology in the higher education sector is not solely dependent on the technology itself, instead, it hinges on the alignment and engagement of employees, from academic faculty to administrative staff. Based on these needs, the study raises the following research question:

*RQ1: What factors affect the implementation effectiveness of technological innovation among employees of higher education institutes in Saudi Arabia?*

This research paper explores the intricate relationship between project leadership, financial resources, top management style, and their collective impact on the effectiveness of technological innovation implementation. The significance of this research lies in its potential to provide valuable insights and evidence-based recommendations to practitioners and scholars in innovation management and organizational leadership. By investigating the interplay between project leadership, financial resources, and top management style, we aim to uncover critical determinants of booming technological innovation implementation. This knowledge can inform strategic decisions, resource allocation, and leadership development within organizations, ultimately enhancing their ability to adapt to technological changes and leverage innovation for sustainable success.

Apart from the introduction section, this paper is structured as follows. Section 2 highlights the literature review and hypotheses development. Section 3 provides the research methods. Section 4 analysis the results. Section 5 discusses the research findings. Section 6 concludes the paper.

## 2. LITERATURE REVIEW AND HYPOTHESES DEVELOPMENT

Project leadership (PL) is pivotal in organizations, influencing outcomes across various domains. Soomro et al. (2019) assert that several vital factors significantly shape leadership behavior. These include the entrepreneurial orientation of leaders, the prevailing organizational culture, and the dynamic external environmental conditions. Furthermore, Strang's (2005) examination of effective transformational project leadership identifies specific traits and behaviors linked to success in project management. In a study by Soomro et al. (2021) conducted in a developing country, a positive association is established between paternalistic leadership and critical organizational aspects. Specifically, paternalistic leadership fosters employee voice and, consequently, enhances employee creativity within entrepreneurial small and medium-sized enterprises (SME) settings. The role of personality traits in bolstering project management and effective project leadership is emphasized in Gehring's (2007) work. Building on this, Soomro and Shah (2022) highlight the transformative power of leadership in fostering corporate entrepreneurship. Transformational leadership, a style known for inspiring employees to engage in innovative and entrepreneurial activities, is revealed to be a significant catalyst in this context. Transitioning to the construction industry, Ghorbani's (2023) study underscores the importance of competencies and leadership characteristics for the success of construction project managers. This research emphasizes the critical role that a manager's skills and leadership style play in achieving project goals. Siddiquei et al. (2023) introduce the concept of temporal leadership, which considers the timing and sequencing of leadership behaviors in the context of sustainable construction projects. This approach is instrumental in aligning leadership actions with different project phases, ultimately contributing to project success. Finally, Kortantamer's (2023) recent study highlights distributed leadership within project management. It emphasizes the positive contributions of involving various stakeholders in sharing leadership responsibilities among project team members and stakeholders, enhancing effective project leadership.

With regard to financial resources (FR), this plays a pivotal role in fostering innovation and organizational performance. Daud et al. (2018) delve into students' financial challenges, underscoring the critical need for financial support within educational settings. Similarly, Ryan (2005) explores the intricate relationship between institutional spending and student engagement, shedding light on how financial resources contribute to an enriched learning experience. Berger and Kostal (2002) discuss the impact of financial resources and regulatory policies on enrollment trends in higher education institutions, further emphasizing the strategic importance of financial planning. Annand (2015) contributes by delving into sustainable financial models tailored for open educational resources, paving the way for accessible and cost-effective education. Moreover, the literature delves into pertinent topics such as financial instruments' role in economic development (Khalitova et al., 2014), the intricate relationship

between financial resources and innovation (Perez-Alaniz et al., 2023), and the transformative impact of financial globalization on technological progress (Zheng et al., 2023). These studies offer comprehensive insights into the multifaceted role of financial resources in education, innovation, and economic development.

The TMS substantially impacts organizational innovation procedures and results (Thite, 2000; Wu et al., 2002; Oke et al., 2009). According to Jia et al. (2018), transformational and open leadership styles are positively related to higher levels of innovation, but autocratic or less participatory leadership may impede innovation efforts. Different leadership styles may also have diverse impacts on innovation. Further, this link may be tempered by elements including organizational learning (Liao et al., 2017), human capital (Costa et al., 2023), knowledge management (Andrej et al., 2023), and worker creativity (Nguyen et al., 2023). These results support the idea that top management style is crucial in determining organizational innovation, with different leadership philosophies and moderating elements affecting the innovation process and results.

Technology innovation is vital for educational institutes as it enhances learning experiences, promotes inclusivity, and prepares students with essential digital skills for the workforce. It also improves administrative efficiency and allows institutions to reach a global audience, contributing to their competitiveness and adaptability in the digital age. The empirical assessment of M. Wang et al. (2023) demonstrates the influence of knowledge sharing within strategic alliances, potentially uncovering the role of trust, communication, and strategic alignment. In the study of Li et al. (2023), green technology innovation in firms affects risk perception, incentives, and behavioral dynamics in

green technology adoption. Similarly, a study unveils a complex web of factors influencing urban innovation and development, potentially emphasizing the pivotal role of governance structures, infrastructure investments, and social dynamics in fostering innovation within urban landscapes (Zhang et al., 2023).

In Saudi Arabia, a comprehensive view of leadership highlights its importance towards performance and is crucial for its growth (Mahamid, 2016). According to Al-Swailem and Elliott (2013), effective leadership is responsible for success in Saudi higher education.

The impact of leadership styles predicts project performance (Eltayeb et al., 2019). In the perception of Alqahtani et al. (2021), the core leadership practices of school principals in Saudi Arabia contribute to the ongoing educational reforms.

Consequently, the existing literature offers valuable insights into various factors that play a pivotal role in fostering IETE, with a focus on higher education in Saudi Arabia. Notably, there is a noticeable gap in the literature concerning the integrated examination of PL, FR and TMS within the Saudi context, despite their recognized importance in driving technological development and innovation (Oke et al., 2009; Liao et al., 2017; Jia et al., 2018; Daud et al., 2018; R. Wang et al., 2023; Li et al., 2023; Zhang et al., 2023; Costa et al., 2023; Siddiquei et al., 2023; Kortantamer, 2023). This study addresses these knowledge gaps by developing a comprehensive conceptual model (Figure 1) aimed at confirming the relationships among these factors, specifically among higher education employees in Saudi Arabia who are intricately linked to technological development and innovation initiatives within their respective educational authorities.

Figure 1. Conceptual model of the study

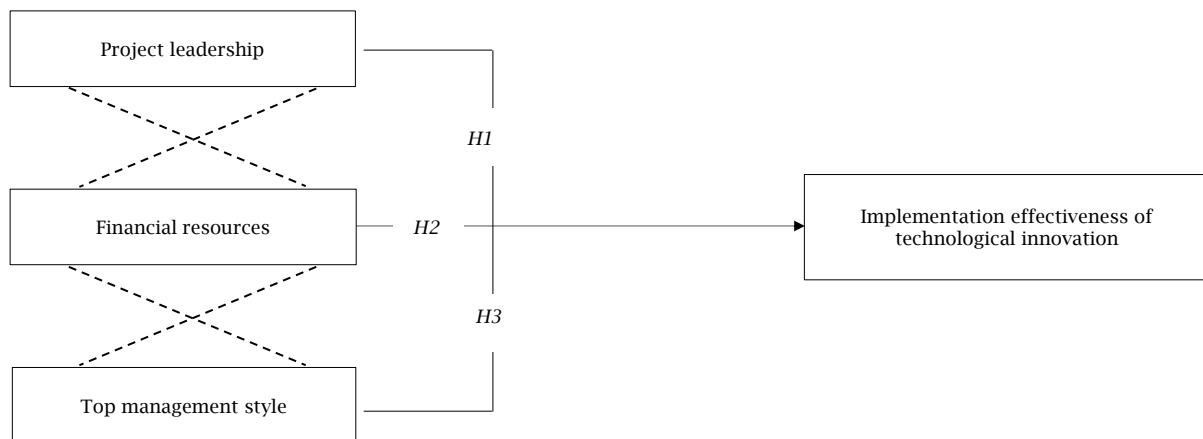

Source: Authors' own conceptualization.

## 2.1. Project leadership and implementation effectiveness of technological innovation

Effective PL is a significant driver of and positively correlates with IETE in diverse domains, including research and development, information systems, product development, education, sustainable innovation, and construction. The influence of PL on IETE may be mediated by factors such as knowledge-

sharing, green learning, and human capital. Moreover, this relationship may exhibit variations in strength across different industries and organizational sizes. This relationship is grounded in synthesizing findings from a range of studies, as evidenced by Elkins and Keller's (2003) literature review emphasizing leadership's role in innovation and Jiang et al. (2001) exploration of PL impact on project outcomes. In a similar direction, the study of Swink (2005) demonstrates a positive and significant

effect of PL on IETE regarding new product innovation. Moreover, scholars like Keane et al. (2020) and Bossink (2007) showed the effect of PL on sustainable innovation. The technology transfer underscores leadership's relevance in fostering innovation in various contexts (Bolatan et al., 2022). Besides, Haider et al. (2023) study on ambidextrous leadership suggests that ambidextrous leadership has a positive effect on innovation (Pham et al., 2023) and that green innovation is affected by transformational leadership. In the empirical assessment of Costa et al. (2023), exploring leadership styles in innovation management further supports the association between leadership and innovation. In entrepreneurship, entrepreneurial leadership's impact on innovation capability adds to the growing body of evidence highlighting the pivotal role of leadership in driving technological innovation across different industries and contexts (Al-Sharif et al., 2023).

Effective PL in Saudi Arabian higher education is pivotal for realizing Vision 2030's technological innovation goals. Education professionals, including those leading initiatives in relevant authorities, play a central role in IETE and fostering collaboration. Leadership influences technology adoption, facilitates knowledge-sharing, and ensures alignment with national ambitions. In this context, leadership styles and human capital development are practical imperatives for nurturing a culture of innovation. Thus, examining the leadership linchpin for advancing technological innovation in Saudi Arabia's higher education sector is necessary. Hence, we proposed:

*H1: PL is significantly related to the IETE in higher education within Saudi Arabia.*

## 2.2. Financial resources and implementation effectiveness of technological innovation

The relationship between financial resources and innovation is multifaceted, as the relevant literature reveals. In various forms, financial support emerges as a vital catalyst for innovation across diverse domains. As explored by Doh and Kim (2014), government initiatives can stimulate innovation among SMEs, particularly in regional industries, underlining the pivotal role of targeted financial aid. As investigated by Liu et al. (2021), rural financial development facilitates the adoption of innovative agricultural practices, thereby enhancing productivity. In the context of clean technology innovation, Erzurumlu and Erzurumlu (2013) highlight the importance of financial incentives in driving the development and deployment of clean technologies. Furthermore, the studies by Jiakui et al. (2023) and Razzaq et al. (2023) shed light on the intertwined nature of financial resources, technological innovation, and sustainability, with green finance and digital finance emerging as crucial enablers of green technological innovation and environmental quality improvements. The relationship is sometimes linear, with papers like Yan and Huang (2021) suggesting potential thresholds beyond which further financial development may yield diminishing returns in innovation efficiency. The researchers like Klein and Knight (2005), Davydenko et al. (2019), Zheng et al. (2023), and Hou et al. (2023) also recognized the positive and significant effect of financial

resources on innovation and performance in several contexts. As a result, the domain literature underscores the multifaceted role of financial resources as a driving force behind innovation, while also highlighting the need for effective resource allocation and contextual considerations in leveraging financial support for innovation success. However, in the realm of higher education in Saudi Arabia, a symbiotic relationship exists between dedicated professionals immersed in technological development and innovation within educational institutions and those who champion transformative initiatives within relevant authorities. Higher education employees, encompassing educators, researchers, and administrators, serve as the driving force behind the integration of cutting-edge technologies into teaching, research, and administrative functions, ensuring that innovation aligns with the specific needs of Saudi Arabian higher education. Simultaneously, the individuals who lead in initiating projects within relevant authorities, such as government bodies or educational councils, catalyze systemic change through funding programs, policy reforms, and strategic directives that incentivize and support innovation across higher education institutions. This dynamic collaboration fosters innovation within the education sector. It extends its impact into broader societal contexts, positioning Saudi Arabia as a global hub for technological advancement and innovation-driven progress. Hence, we expect:

*H2: FR is significantly related to the IETE in higher education within Saudi Arabia.*

## 2.3. Top management style and implementation effectiveness of technological innovation

The TMS significantly influences organizational innovation processes and outcomes (Thite, 2000; Wu et al., 2002; Oke et al., 2009). Different leadership styles may have varying effects on innovation, with transformational and open leadership styles positively associated with higher levels of innovation (Jia et al., 2018), while autocratic or less participative leadership may hinder innovation efforts (Nguyen et al., 2023). Moreover, this relationship may be moderated by factors such as organizational learning (Liao et al., 2017), human capital (Costa et al., 2023), knowledge management (Andrej et al., 2023), and employee creativity (Nguyen et al., 2023). These findings collectively support the hypothesis that top management style plays a pivotal role in shaping organizational innovation, with various leadership styles and moderating factors influencing the innovation process and outcomes.

Consequently, testing the association between TMS and IETE among higher education employees immersed in technological innovation and those initiating initiatives in relevant authorities in Saudi Arabia is paramount for several reasons. This research aligns with Vision 2030's commitment to innovation and its centrality in higher education. The COVID-19 pandemic's impact on digital education accentuates its urgency. Insights from this study can inform policy decisions, bridge gaps, and optimize resource allocation, fostering innovation in higher education. Moreover, it offers a valuable reference point for global education systems grappling with similar challenges, contributing to

the broader discourse on the role of higher education in fostering innovation. Thus, we suggest:

*H3: TMS is significantly related to the IETE in higher education within Saudi Arabia.*

### 3. METHODS

#### 3.1. Survey strategy and respondents

The study employed a comprehensive survey strategy, meticulously gathering cross-sectional data from various sources and participants. This approach allowed us to capture a snapshot of the phenomenon under investigation at a specific time, providing valuable insights into the dynamics of the subject matter (Hair et al., 2019). Through careful data collection and rigorous analysis, we aimed to uncover patterns, trends, and correlations that would help us better understand the complexities of our research topic. In conducting studies of IETE, TMS, FR, and PL, several scholars like Liao et al. (2017), Jia et al. (2018), Liu et al. (2021), Nguyen et al. (2023), Costa et al. (2023), Andrej et al. (2023), Nguyen et al. (2023) and Razzaq et al. (2023) applied the same technique to conduct their studies.

The researchers focused on employees of higher educational institutes in Saudi Arabia. The study's concentration on employees within Saudi Arabia's higher educational institutes carries considerable significance across multiple domains. In the realm of technology innovation, this focus enables a deeper understanding of the factors influencing the adoption and advancement of technology within educational settings (Eltayeb et al., 2019; Alqahtani et al., 2021). Moreover, it offers insights into project leadership dynamics, unveiling valuable lessons on effective leadership strategies for research, curriculum development, and community initiatives (Akinwale & AboAlsamh, 2023). Besides, the study sheds light on the prevalent TMS, FR, and PL within these institutions, thereby contributing to enhancing leadership practices and organizational performance.

#### 3.2. Survey tool and assessment

The researchers employed a survey questionnaire to gather participants' responses. Before data collection, a pilot study was conducted to verify the questionnaire's reliability and validity. Fourteen questionnaires were administered to assess these assumptions. The questionnaire was administered in English and Arabic to accommodate a diverse respondent base. To ascertain reliability, Cronbach's alpha ( $\alpha$ ) was employed to assess internal consistency among the questionnaire items. The overall reliability score yielded a robust value of 0.857, while individual factors consistently registered above the recommended threshold of 0.70 (Hair et al., 2019). Besides, to enhance the questionnaire's validity, it was reviewed by two university professors. One professor specialized in management, while the other possessed expertise in contemporary trends in survey research and structural equation modeling (SEM) analysis. Their valuable input was sought to evaluate the questionnaire items' face and content validity. The outcome of this evaluation confirmed the adequacy of both reliability and validity assumptions, thus paving the way for the commencement of large-scale data collection.

#### 3.3. Data collection process and respondents ethics

The researchers employed a dual approach to data collection, encompassing personal visits and online surveys. In the case of personal visits, the researchers physically visited higher education institutions in Saudi Arabia and gathered responses using a convenience sampling method. Simultaneously, an online survey was administered by distributing mail questionnaires and providing links to the online questionnaire via WhatsApp groups, which were specially established during the pandemic.

In strict adherence to ethical protocols, the researchers sought the participants' permission for voluntary participation in the study. They assured respondents of the utmost privacy and confidentiality, emphasizing that their responses would be used exclusively for educational purposes. Before data collection, the researchers communicated the study's aims and objectives. Once participants expressed their willingness to partake, they were requested to provide their consent by signing a formal consent form. Only then did the researchers proceed to collect their responses. This meticulous approach yielded a total of 220 valid responses, which were subsequently employed in the final assessment of the study.

#### 3.4. Measures

To measure PL, FR, TMS, and IETE, the following items were used.

**Project leadership (PL):** The researchers used seven items adopted from Lindgren and Packendorff (2009) and Packendorff et al. (2014) to measure PL. The sample content of the scale is "*Staff with skills needed to complete project*".

**Financial resources (FR):** The researchers borrowed seven items from the study of Berger and Kostal (2002) and Ryan (2005) to assess the FR, with the sample item as "*Any person who showed interest and had time for the project*".

**Top management style (TMS):** The researchers applied eight items to gauge TMS. These items are adopted from scholars like Wu et al. (2002) and Kihn (2010). The sample item of the scale is "*University management has actively pushed to make the project a success*".

**Implementation effectiveness of technological innovation (IETE):** The IETE factor was measured on seven items adopted from Kihn (2010) and Sawang and Unsworth (2011), with a sample content "*Nature of the project we were undertaking meant had high propensity to succeed*".

## 4. ANALYSIS

### 4.1. Demographic profile

The demographic profile suggests that a majority (70.90% or  $n = 156$ ) were males against females (29.09% or  $n = 64$ ). Regarding the age of respondents, a majority (55.45% or  $n = 122$ ) were between 31-40; 28.18% ( $n = 62$ ) were 20-30; 14.55% ( $n = 32$ ) were 41-50 and only 1.82% ( $n = 4$ ) were 51 years and above. The educational level indicator

suggests a majority of respondents (52.73% or n = 116) were bachelor, 19.09% (n = 42) were diploma, 14.55% (n = 32) were masters, and only 13.63% (n = 30) were high school education. With regard to work experience, a majority of respondents (40% or n = 88) had 6-10 years; 34.55%

(n = 76) were < 5 years, and 25.45% (n = 56) were > 15 years. A majority of respondents (83.64% or n = 184) were staff individuals; 10% (n = 22) were supervisors, and only 6.36% (n = 14) were heads of departments who contributed to the study (Table 1).

**Table 1.** Demography

Construct	Category	Frequency	Percent
Gender	Male	156	70.90
	Female	64	29.09
	Total	220	100.0
Age (years)	20-30	62	28.18
	31-40	122	55.45
	41-50	32	14.55
	51 and above	04	1.82
	Total	220	100.0
Educational level	High school	30	13.63
	Diploma	42	19.09
	Bachelor	116	52.73
	Masters	32	14.55
	Total	220	100.0
Work experience (years)	< 5	76	34.55
	6-10	88	40.00
	> 15	56	25.45
	Total	220	100.0
Position	Supervisor	22	10.00
	Head of a department	14	6.36
	Staff	184	83.64
	Total	220	100.0

Source: Authors' calculation.

#### 4.2. Measurement model

The measurement model is assessed through composite reliability (CR), Cronbach's alpha ( $\alpha$ ), and the average variance extracted (AVE), as suggested by (Hair et al., 2014). The values of CR appeared greater than 0.70 for the rest of the constructs, along with factor loading also greater than 0.70 (Hair et al.,

2014). However, we dropped some items, such as PL7, FR6, FR7, TMS6, and IETE4, which do not appear with the required values (> 0.70) (Hair et al., 2019). Moreover, the values of AVE for all the constructs appeared as > 0.50, which ensured the good AVE of the model (Hair et al., 2019). Consequently, we achieved convergent validity among all the study constructs (Table 2 and Figure 2).

**Table 2.** Measurement model

Item code	Loadings	CR	AVE	Alpha ( $\alpha$ )
FR1	0.791	0.896	0.634	0.855
FR2	0.800			
FR3	0.788			
FR4	0.768			
FR5	0.831			
IETE1	0.794	0.908	0.621	0.877
IETE2	0.779			
IETE3	0.773			
IETE5	0.743			
IETE6	0.797			
IETE7	0.839			
PL1	0.947			
PL2	0.969			
PL3	0.953			
PL4	0.954			
PL5	0.974			
PL6	0.847			
TMS1	0.869	0.977	0.877	0.971
TMS2	0.979			
TMS3	0.947			
TMS4	0.962			
TMS5	0.976			
TMS7	0.879			

Note: Deleted items: PL7, FR6, FR7, TMS6, IETE4; FR = financial resources; PL = project leadership; TMS = top management style; IETE = implementation effectiveness of technological innovation.

Figure 2. Factor loadings

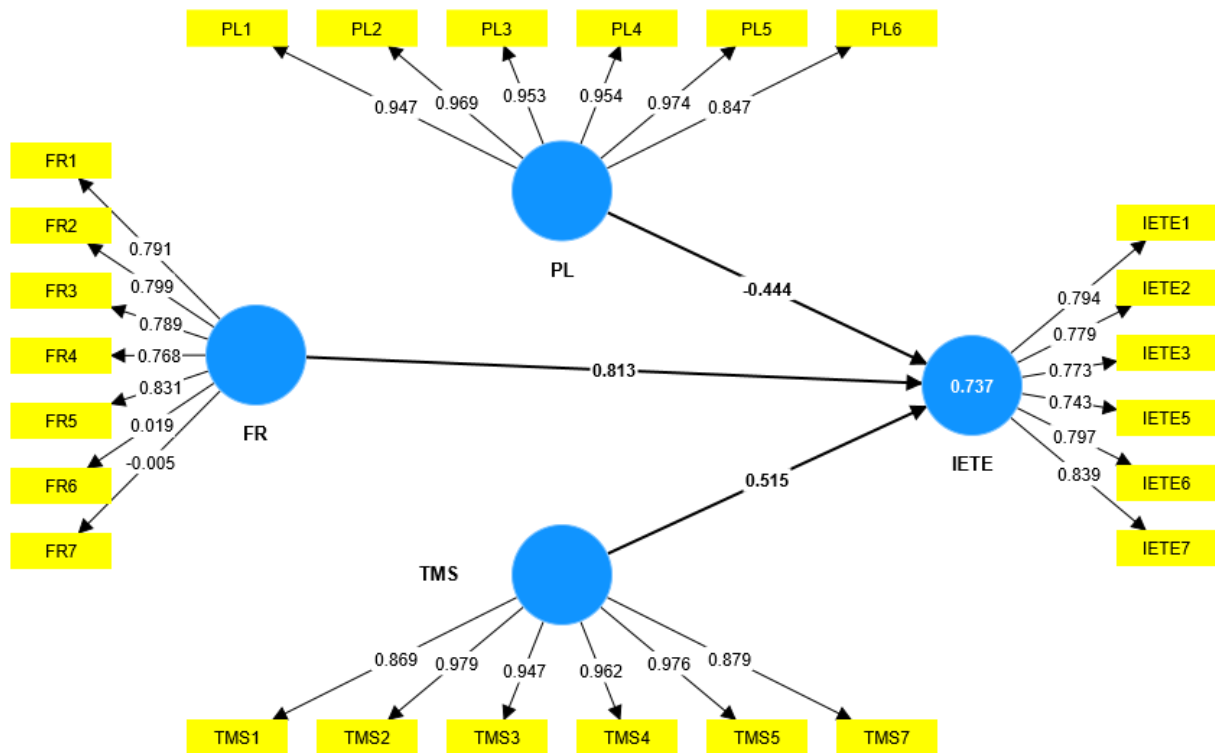

Source: Authors' calculation.

Moreover, we gauged discriminant validity (DV) as it refers to the degree to which construct is distinct from other constructs (Hair et al., 2019). According to Hair et al. (2019), when we examined the values of AVE with the squared

correlation between the construct and other constructs (Fornell & Larcker, 1981), we discovered that all AVE scores were higher. As a result, we validated the achievement of excellent DV (Table 3).

Table 3. The heterotrait-monotrait ratio of correlations (HTMT) results

Constructs	1	2	3	4
1. FR				
2. IETE	0.854			
3. PL	0.622	0.612		
4. TMS	0.572	0.58	0.721	

Note: FR = financial resources; IETE = implementation effectiveness of technological innovation, PL = project leadership; TMS = top management style.

### 4.3. Structural model

We applied a structural equation model (SEM) to estimate the proposed paths using SmartPLS 4 as the best software (Ringle et al., 2022). The analysis showed a negative significant effect of PL on IETE ( $H1 = \beta = -0.446$ ;  $p < 0.01$ ). Hence,  $H1$  is rejected.

Besides, the path between FR and IETE is positively significant ( $H2 = \beta = 0.813$ ;  $p < 0.01$ ), which accepted the  $H2$ . Finally, the direction between TMS and IETE is positive and significant ( $H3 = (\beta) = 0.516$ ;  $p < 0.01$ ). Consequently,  $H3$  is supported (Table 4 and Figure 3).

Table 4. Path results

Hypothesis	Proposed paths	Std. ( $\beta$ )	Mean	Std. dev	t-value	p-value	Decision
$H1$	PL → IETE	-0.446	-0.453	0.153	2.911	0.004	Rejected
$H2$	FR → IETE	0.813	0.819	0.045	18.124	0.000	Accepted
$H3$	TMS → IETE	0.516	0.52	0.154	3.342	0.001	Accepted

Note: \*  $p < 0.05$ ; \*\*  $p < 0.01$ ; \*\*\*  $p < 0.001$ ; FR = financial resources; PL = project leadership; TMS = top management style; IETE = implementation effectiveness of technological innovation.

Figure 3. Path analysis

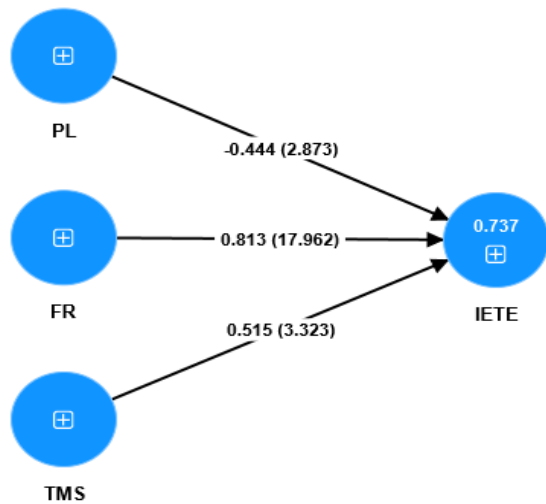

Note: FR = financial resources; PL = project leadership; TMS = top management style; IETE = implementation effectiveness of technological innovation.

Source: Authors' calculation.

## 5. DISCUSSION

The present study explored the factors influencing the implementation of technological innovation in higher education within the context of Saudi Arabia. The path analysis unearthed a rather unexpected outcome, revealing an adverse effect of PL on IETE. This outcome challenged our initial hypothesis (*H1*) and prompted us to delve deeper into its implications. Interestingly, these results stand in contrast to the findings of numerous esteemed scholars in the field, such as Jiang et al. (2001), Elkins and Keller (2003), Swink (2005), Keane et al. (2020), Bolatan et al. (2022), Haider et al. (2023), Pham et al. (2023), and Costa et al. (2023), who have consistently asserted the positive and influential role of PL on the IETE. These prior studies have convincingly argued that effective project leadership is pivotal in driving successful technological innovations in educational settings. In light of these contradictory findings, it becomes imperative to scrutinize the nuances and underlying mechanisms that led to this unexpected outcome. One possible interpretation could be that the staff members in the context of our study needed to possess the skills necessary to complete technological projects effectively. Moreover, it is conceivable that low levels of effectiveness marked their previous experiences in managing projects. Additionally, these staff members might have needed to demonstrate the ability to adequately represent the interests and strategic direction of the institution's management. These intriguing results raise critical questions about the dynamics of project leadership and technological innovation within higher education in Saudi Arabia. They call for a deeper exploration of the unique contextual factors that may be at play. In this setting, they suggest reevaluating established assumptions regarding the relationship between PL and the IETE.

Moreover, the study found a positive and significant effect of FR and TMS on IETE among the employees of higher educational institutes in Saudi Arabia. These results are accorded with

previous studies (Doh & Kim, 2014; Jia et al., 2018; Davydenko et al., 2019; Liu et al., 2021; Yan & Huang, 2021; Jiakui et al., 2023; Razzaq et al., 2023; Zheng et al., 2023; Hou et al., 2023; Nguyen et al., 2023; Costa et al., 2023). These thought-provoking results offer several significant insights into the landscape of project implementation within Saudi Arabian higher education institutions. Notably, they suggest high enthusiasm and availability among employees for project involvement. Furthermore, the study underscores a commendable commitment to inclusive participation, as evidenced by the engagement of every section member. However, the surprising discovery of a negative impact from staff who had previously managed projects effectively raises intriguing questions about these managers' specific practices or attributes and their alignment with project goals. The presence of a skilled team, though typically seen as advantageous, did not necessarily correlate with improved project outcomes. Besides, the involvement of staff working in sections directly impacted by the project did not consistently yield positive results, emphasizing the complex nature of managing projects with multifaceted organizational implications. Finally, the study alludes to the role of the proposal initiator, but further investigation is needed to discern the extent of their influence on project outcomes. The administration of the higher education institution is steadfastly dedicated to the project's proper execution and actively works to ensure its success. Higher education administrators and team captains emphasized the significance of their institutions' projects. The team leader often calls meetings and expresses interest in the project's achievements and difficulties. Management and team leaders outlined the project's objectives in great detail. Management stepped in if there was a bottleneck, such as in procurement. Successful project participants received rewards.

## 6. CONCLUSION

The overall results of the study reveal that the current PL negatively impacts IETE in Saudi Arabian higher education. This underscores the urgency for reevaluating leadership strategies tailored to this context. In contrast, our research highlights the significant positive effects of FR and TMS on IETE, which suggest that adequate funding and visionary leadership enhance IETE, fostering growth and competitiveness in educational institutions. Recognizing these findings, it's clear that the right resources and management approaches can overcome challenges, offering a roadmap for effective tech integration in Saudi higher education.

The study findings support educational institutions to critically assess their PL practices and consider adapting them to the unique challenges of IETE. This might involve retraining or developing leaders with a focus on innovation management. The study would ensure a robust allocation of FR is crucial for the successful IETE. It would also help institutions to prioritize investments in technology infrastructure, training, and development to support these initiatives effectively. In light of the study findings, top management may adopt a visionary leadership style that encourages innovation,



embraces change, and sets a clear strategic direction for technological adoption. This proactive approach can help navigate the complexities of technology integration. The study would assist educational institutions to promote collaboration between project leaders, top management, and stakeholders to align efforts and resources effectively. The findings also encourage sharing best practices and experiences among educational institutions within Saudi Arabia to create a supportive network for IETE. Regarding theoretical implications, the study supports developing theories emphasizing innovation management. The study would encourage researchers to apply this framework in different contexts, including Europe, Asia, and other Gulf countries.

The study is limited to a specific theoretical domain, suggesting broader theoretical frameworks are needed in future investigations. This research

focus on quantitative methods may have overlooked qualitative nuances, emphasizing the importance of incorporating qualitative approaches for a holistic view. Besides, the study's context in Saudi Arabian higher education is insightful, but recognizing contextual variations across different settings is crucial. Lastly, with a sample size of 220 participants.

Future research in IETE in education should broaden its theoretical scope, adopting interdisciplinary frameworks. Employing mixed-methods approaches to capture both quantitative data and qualitative nuances is crucial. Comparative, cross-cultural studies can unveil context-specific insights, while larger and more diverse samples enhance external validity. Longitudinal investigations tracking innovation evolution and comparative analyses of leadership models offer promising directions for advancing this field.

## REFERENCES

- Akinwale, Y. O., & AboAlsamh, H. M. (2023). Technology innovation and healthcare performance among healthcare organizations in Saudi Arabia: A structural equation model analysis. *Sustainability*, 15(5), Article 3962. <https://doi.org/10.3390/su15053962>
- Alqahtani, A. S., Noman, M., & Kaur, A. (2021). Core leadership practices of school principals in the Kingdom of Saudi Arabia. *Educational Management Administration & Leadership*, 49(2), 321-335. <https://doi.org/10.1177/1741143220901857>
- Al-Sharif, A. M., Ali, M. H., Jaharuddin, N. S., Abdulsamad, A., & Jandab, A. (2023). The role of innovation capability in the relationship between entrepreneurial leadership and innovation performance in the SMEs service industry. *Advances in Social Sciences Research Journal*, 10(1), 264-278. <https://doi.org/10.14738/assrj.101.13802>
- Al-Swailem, O., & Elliott, G. (2013). The learning experiences of Saudi Arabian higher education leadership: Characteristics for global success. In L. Smith & A. Abouammoh (Eds.), *Higher education in Saudi Arabia: Achievements, challenges and opportunities* (pp. 37-47). Springer Dordrecht. [https://doi.org/10.1007/978-94-007-6321-0\\_4](https://doi.org/10.1007/978-94-007-6321-0_4)
- Andrej, N., Breznik, K., & Natek, S. (2023). Managing knowledge to improve performance: The impact of leadership style and knowledge management on organizational performance with moderation effects via PLS-SEM. *Journal of the Knowledge Economy*, 14(2), 1672-1701. <https://doi.org/10.1007/s13132-022-00957-4>
- Annand, D. (2015). Developing a sustainable financial model in higher education for open educational resources. *The International Review of Research in Open and Distributed Learning*, 16(5), 1-15. <https://doi.org/10.19173/irrodl.v16i5.2133>
- Bel, R. (2009). Leadership and innovation: Learning from the best. *Global Business and Organizational Excellence*, 29(2), 47-60. <https://doi.org/10.1002/joe.20308>
- Berger, M. C., & Kostal, T. (2002). Financial resources, regulation, and enrollment in US public higher education. *Economics of Education Review*, 21(2), 101-110. [https://doi.org/10.1016/S0272-7757\(00\)00065-0](https://doi.org/10.1016/S0272-7757(00)00065-0)
- Bolatan, G. I. S., Giadedi, A., & Daim, T. (2022). Innovation leadership through technology transfer: Case of Turkish industry. *Technology in Society*, 68, Article 101909. <https://doi.org/10.1016/j.techsoc.2022.101909>
- Bossink, B. A. G. (2007). Leadership for sustainable innovation. *International Journal of Technology Management & Sustainable Development*, 6(2), 135-149. [https://doi.org/10.1386/ijtm.6.2.135\\_1](https://doi.org/10.1386/ijtm.6.2.135_1)
- Caballero, R., Galache, T., Gómez, T., Molina, J., & Torrico, A. (2001). Efficient assignment of financial resources within a university system. Study of the university of Malaga. *European Journal of Operational Research*, 133(2), 298-309. [https://doi.org/10.1016/S0377-2217\(00\)00299-X](https://doi.org/10.1016/S0377-2217(00)00299-X)
- Costa, J., Pádua, M., & Moreira, A. C. (2023). Leadership styles and innovation management: What is the role of human capital? *Administrative Sciences*, 13(2), Article 47. <https://doi.org/10.3390/admsci13020047>
- Daud, N., Norwani, N. M., & Yusof, R. (2018). Students' financial problems in higher education institutions. *International Journal of Academic Research in Business and Social Sciences*, 8(10), 1558-1565. <https://doi.org/10.6007/IJARBS/v8-i10/5312>
- Davydenko, N., Buriak, A., & Titenko, Z. (2019). Financial support for the development of innovation activities. *Intelektinė Ekonomika*, 13(2), 144-151. <https://www.ceeol.com/search/article-detail?id=831306>
- Doh, S., & Kim, B. (2014). Government support for SME innovations in the regional industries: The case of government financial support program in South Korea. *Research Policy*, 43(9), 1557-1569. <https://doi.org/10.1016/j.respol.2014.05.001>
- Elkins, T. J., & Keller, R. T. (2003). Best practices for R&D project leaders: Lessons from thirty years of leadership research. *International Journal of Innovation and Technology Management*, 1(1), 3-16. <https://doi.org/10.1142/S0219877004000052>
- Eltayeb, T., Ahmad, S., & Al-Hajri, M. (2019). The effect of leadership style on project performance: An empirical investigation in Saudi Arabia. *Academy of Management Global Proceedings*, 2019. <https://journals.aom.org/doi/abs/10.5465/amgblproc.slovenia.2019.0186.abs>
- Erzurumlu, S. S., & Erzurumlu, Y. O. (2013). Development and deployment drivers of clean technology innovations. *The Journal of High Technology Management Research*, 24(2), 100-108. <https://doi.org/10.1016/j.hitech.2013.09.001>

- Fornell, C., & Larcker, D. F. (1981). Evaluating structural equation models with unobservable variables and measurement error. *Journal of Marketing Research*, 18(1), 39–50. <https://doi.org/10.1177/002224378101800104>
- Gehring, D. R. (2007). Applying traits theory of leadership to project management. *Project Management Journal*, 38(1), 44–54. <https://doi.org/10.1177/875697280703800105>
- Ghorbani, A. (2023). A review of successful construction project managers' competencies and leadership profile. *Journal of Rehabilitation in Civil Engineering*, 11(1), 76–95. <https://doi.org/10.22075/jrce.2022.24638.1560>
- Haider, S. A., Zubair, M., Tehseen, S., Iqbal, S., & Sohail, M. (2023). How does ambidextrous leadership promote innovation in project-based construction companies? Through mediating role of knowledge-sharing and moderating role of innovativeness. *European Journal of Innovation Management*, 26(1), 99–118. <https://doi.org/10.1108/EJIM-02-2021-0083>
- Hair, J. F., Jr., Sarstedt, M., Hopkins, L., & Kuppelwieser, V. G. (2014). Partial least squares structural equation modeling (PLS-SEM): An emerging tool in business research. *European Business Review*, 26(2), 106–121. <https://doi.org/10.1108/EBR-10-2013-0128>
- Hair, J. F., Risher, J. J., Sarstedt, M., & Ringle, C. M. (2019). When to use and how to report the results of PLS-SEM. *European Business Review*, 31(1), 2–24. <https://doi.org/10.1108/EBR-11-2018-0203>
- Hou, H., Zhu, Y., Wang, J., & Zhang, M. (2023). Will green financial policy help improve China's environmental quality? The role of digital finance and green technology innovation. *Environmental Science and Pollution Research*, 30(4), 10527–10539. <https://doi.org/10.1007/s11356-022-22887-z>
- Jia, X., Chen, J., Mei, L., & Wu, Q. (2018). How leadership matters in organizational innovation: A perspective of openness. *Management Decision*, 56(1), 6–25. <https://doi.org/10.1108/MD-04-2017-0415>
- Jiakui, C., Abbas, J., Najam, H., Liu, J., & Abbas, J. (2023). Green technological innovation, green finance, and financial development and their role in green total factor productivity: Empirical insights from China. *Journal of Cleaner Production*, 382, Article 135131. <https://doi.org/10.1016/j.jclepro.2022.135131>
- Jiang, J. J., Klein, G., & Chen, H. G. (2001). The relative influence of IS project implementation policies and project leadership on eventual outcomes. *Project Management Journal*, 32(3), 49–55. <https://doi.org/10.1177/875697280103200307>
- Keane, T., Boden, M., Chalmers, C., & Williams, M. (2020). Effective principal leadership influencing technology innovation in the classroom. *Education and Information Technologies*, 25(6), 5321–5338. <https://doi.org/10.1007/s10639-020-10217-0>
- Khalitova, M. M., Praliev, G. S., Panzabekova, A. Z., Andreeva, Z. M., & Dzhubaliyeva, Z. A. (2014). Financial instruments of state regulation industrial and innovative development of Kazakhstan economy. *Life Science Journal*, 11(10), 369–378. [https://www.lifesciencesite.com/ljsj/life1110s/070\\_25647life1110s14\\_369\\_378.pdf](https://www.lifesciencesite.com/ljsj/life1110s/070_25647life1110s14_369_378.pdf)
- Kihn, L. A. (2010). An empirical investigation of the principal top management styles in the emphasis of multiple forms of controls. *International Journal of Accounting, Auditing and Performance Evaluation (IJAAP)*, 6(1), 108–127. <https://doi.org/10.1504/IJAAP.2010.030481>
- Klein, K. J., & Knight, A. P. (2005). Innovation implementation: Overcoming the challenge. *Current Directions in Psychological Science*, 14(5), 243–246. <https://doi.org/10.1111/j.0963-7214.2005.00373.x>
- Kortantamer, D. (2023). Distributed leadership in projects: The contributions of stakeholders. *Project Management Journal*, 54(2), 179–193. <https://doi.org/10.1177/87569728221143049>
- Li, C., Wang, Z., & Wang, L. (2023). Factors affecting firms' green technology innovation: An evolutionary game based on prospect theory. *Environmental Monitoring and Assessment*, 195(227). <https://doi.org/10.1007/s10661-022-10835-w>
- Liao, S.-H., Chen, C.-C., Hu, D.-C., Chung, Y.-C., & Liu, C.-L. (2017). Assessing the influence of leadership style, organizational learning and organizational innovation. *Leadership & Organization Development Journal*, 38(5), 590–609. <https://doi.org/10.1108/LODJ-11-2015-0261>
- Lindgren, M., & Packendorff, J. (2009). Project leadership revisited: Towards distributed leadership perspectives in project research. *International Journal of Project Organisation and Management*, 1(3), 285–308. <https://doi.org/10.1504/IJPOM.2009.027540>
- Liu, Y., Ji, D., Zhang, L., An, J., & Sun, W. (2021). Rural financial development impacts on agricultural technology innovation: Evidence from China. *International Journal of Environmental Research and Public Health*, 18(3), Article 1110. <https://doi.org/10.3390/ijerph18031110>
- Mahamid, I. (2016). Factors contributing to poor performance in construction projects: Studies of Saudi Arabia. *Australian Journal of Multi-Disciplinary Engineering*, 12(1), 27–38. <https://doi.org/10.1080/14488388.2016.1243034>
- Mahardhani, A. J. (2023). The role of public policy in fostering technological innovation and sustainability. *Journal of Contemporary Administration and Management (ADMAN)*, 1(2), 47–53. <https://doi.org/10.61100/adman.v1i2.22>
- Nguyen, M., Sharma, P., & Malik, A. (2023). Leadership styles and employee creativity: The interactive impact of online knowledge sharing and organizational innovation. *Journal of Knowledge Management*. <https://doi.org/10.1108/JKM-01-2023-0014>
- Oduami, K. T., Iyagba, R. R. O., & Omirin, M. M. (2003). The relationship between project leadership, team composition and construction project performance in Nigeria. *International Journal of Project Management*, 21(7), 519–527. [https://doi.org/10.1016/S0263-7863\(02\)00059-5](https://doi.org/10.1016/S0263-7863(02)00059-5)
- Oke, A., Munshi, N., & Walumbwa, F. O. (2009). The influence of leadership on innovation processes and activities. *Organizational Dynamics*, 38(1), 64–72. <https://doi.org/10.1016/j.orgdyn.2008.10.005>
- Packendorff, J., Crevani, L., & Lindgren, M. (2014). Project leadership in becoming: A process study of an organizational change project. *Project Management Journal*, 45(3), 5–20. <https://doi.org/10.1002/pmj.21418>
- Perez-Alaniz, M., Lenihan, H., Doran, J., & Hewitt-Dundas, N. (2023). Financial resources for research and innovation in small and larger firms: Is it a case of the more you have, the more you do? *Industry and Innovation*, 30(2), 189–232. <https://doi.org/10.1080/13662716.2022.2036597>
- Pham, H. T., Pham, T., Truong Quang, H., & Dang, C. N. (2023). Impact of transformational leadership on green learning and green innovation in construction supply chains. *Engineering, Construction and Architectural Management*, 30(5), 1883–1901. <https://doi.org/10.1108/ECAM-05-2021-0379>

- Razzaq, A., Sharif, A., Ozturk, I., & Skare, M. (2023). Asymmetric influence of digital finance, and renewable energy technology innovation on green growth in China. *Renewable Energy*, 202, 310-319. <https://doi.org/10.1016/j.renene.2022.11.082>
- Ringle, C. M., Wende, S., & Becker, J. M. (2022). *SmartPLS 4*. <http://www.smartpls.com>
- Ryan, J. F. (2005). Institutional expenditures and student engagement: A role for financial resources in enhancing student learning and development? *Research in Higher Education*, 46, 235-249. <https://doi.org/10.1007/s11162-004-1601-x>
- Sawang, S., & Unsworth, K. L. (2011). A model of organizational innovation implementation effectiveness in small to medium firms. *International Journal of Innovation Management*, 15(05), 989-1011. <https://doi.org/10.1142/S1363919611003398>
- Siddiquei, A. N., Imam, H., & Asmi, F. (2023). How and when temporal leadership facilitates the success of sustainable construction projects. *Engineering, Construction and Architectural Management*. <https://doi.org/10.1108/ECAM-10-2022-0965>
- Somech, A. (2006). The effects of leadership style and team process on performance and innovation in functionally heterogeneous teams. *Journal of Management*, 32(1), 132-157. <https://doi.org/10.1177/0149206305277799>
- Soomro, B. A., & Shah, N. (2022). Robustness of the transformational leadership towards corporate entrepreneurship. *Journal of Public Affairs*, 22(2), Article e2509. <https://doi.org/10.1002/pa.2509>
- Soomro, B. A., Memon, M., & Shah, N. (2021). Paternalistic leadership style, employee voice and creativity among entrepreneurs: Empirical evidence from SMEs of a developing country. *Management Decision*, 59(2), 285-305. <https://doi.org/10.1108/MD-11-2018-1207>
- Soomro, B. A., Shah, N., & Mangi, S. (2019). Factors affecting the entrepreneurial leadership in small-and medium-sized enterprises (SMEs) of Pakistan: An empirical evidence. *World Journal of Entrepreneurship, Management and Sustainable Development*, 15(1), 31-44. <https://doi.org/10.1108/WJEMSD-05-2018-0054>
- Strang, K. D. (2005). Examining effective and ineffective transformational project leadership. *Team Performance Management*, 11(3/4), 68-103. <https://doi.org/10.1108/13527590510606299>
- Strang, K. D. (2007). Examining effective technology project leadership traits and behaviors. *Computers in Human Behavior*, 23(1), 424-462. <https://doi.org/10.1016/j.chb.2004.10.041>
- Swink, M. (2005). Exploring new product innovation types and performance: The roles of project leadership, functional influences, and design integration. *International Journal of Product Development (IJPD)*, 1(3/4), 241-260. <https://doi.org/10.1504/IJPD.2005.005941>
- Thite, M. (2000). Leadership styles in information technology projects. *International Journal of Project Management*, 18(4), 235-241. [https://doi.org/10.1016/S0263-7863\(99\)00021-6](https://doi.org/10.1016/S0263-7863(99)00021-6)
- Wadood, S., Gharleghi, B., & Samadi, B. (2016). Influence of change in management in technological enterprises. *Procedia Economics and Finance*, 37, 129-136. [https://doi.org/10.1016/S2212-5671\(16\)30103-4](https://doi.org/10.1016/S2212-5671(16)30103-4)
- Wang, M., Wang, Y., & Mardani, A. (2023). Empirical analysis of the influencing factors of knowledge sharing in industrial technology innovation strategic alliances. *Journal of Business Research*, 157, Article 113635. <https://doi.org/10.1016/j.jbusres.2022.113635>
- Wang, R., Usman, M., Radulescu, M., Cifuentes-Faura, J., & Balsalobre-Lorente, D. (2023). Achieving ecological sustainability through technological innovations, financial development, foreign direct investment, and energy consumption in developing European countries. *Gondwana Research*, 119, 138-152. <https://doi.org/10.1016/j.gr.2023.02.023>
- Wu, W.-Y., Chiang, C.-Y., & Jiang, J.-S. (2002). Interrelationships between TMT management styles and organizational innovation. *Industrial Management & Data Systems*, 102(3), 171-183. <https://doi.org/10.1108/02635570210421363>
- Yan, X., & Huang, Y. (2021). Is there a nonlinear economic threshold effect of financial development on the efficiency of sci-tech innovation? An empirical test from the Yangtze River economic belt. *Growth and Change*, 52(3), 1387-1409. <https://doi.org/10.1111/grow.12509>
- Yikun, Z., Leong, L. W., Abu-Rumman, A., Shraah, A. A., & Hishan, S. S. (2023). Green growth, governance, and green technology innovation. How effective towards SDGs in G7 countries? *Economic Research-Ekonomska Istraživanja*, 36(2), Article 2145984. <https://doi.org/10.1080/1331677X.2022.2145984>
- Zaman, U., Naeni, L. M., Huda, N. ul, & Khwaja, M. G. (2023). Time flies when you are having fun: The mediating effects of project opportunity management in the relationship between project leaders' self-efficacy and multidimensional project success. *Project Management Journal*, 54(2), 132-148. <https://doi.org/10.1177/87569728221134524>
- Zhang, J.-X., Cheng, J.-W., Philbin, S. P., Ballesteros-Perez, P., Skitmore, M., & Wang, G. (2023). Influencing factors of urban innovation and development: A grounded theory analysis. *Environment, Development and Sustainability*, 25, 2079-2104. <https://doi.org/10.1007/s10668-022-02151-7>
- Zheng, M., Feng, G.-F., Wang, Q.-J., & Chang, C.-P. (2023). Financial globalization and technological innovation: International evidence. *Economic Systems*, 47(1), Article 101048. <https://doi.org/10.1016/j.ecosys.2022.101048>